

WARING
COMMERCIAL

MX1200XTEK

64 oz. BPA-Free copolyester container UK

MX1200XTEKS

64 oz. stainless steel container UK

MX1200XTPEK

48 oz. BPA-Free copolyester container UK

MX1200XTPSEK

48 oz. BPA-Free copolyester container with Sound Enclosure UK

MX1200XTSEK

64 oz. BPA-Free copolyester container with Sound Enclosure UK

MX1200XTSEKS

64 oz. stainless container with Sound Enclosure UK

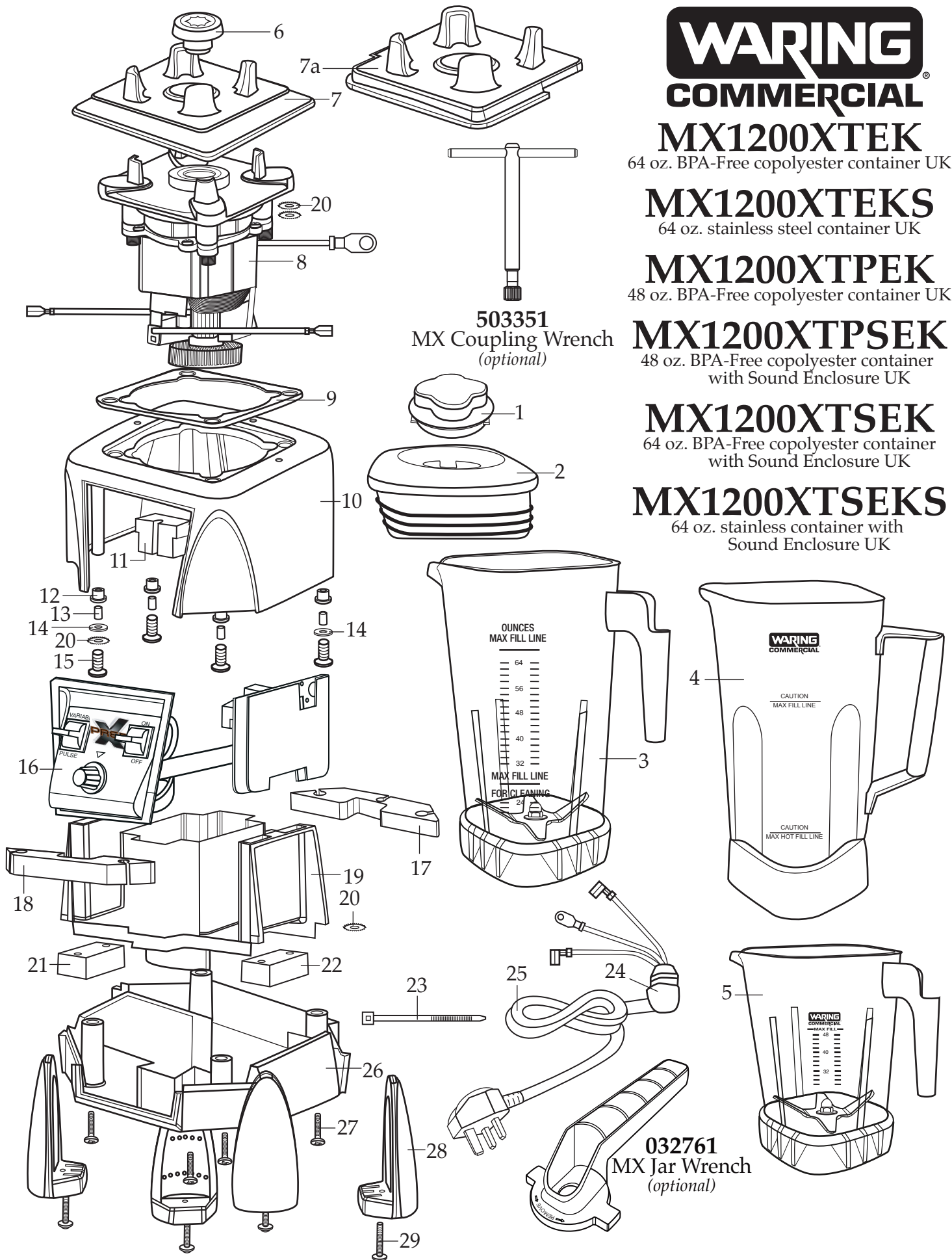

Catalog**Model**

MX1200XTEK
 MX1200XTEKS
 MX1200XTPEK
 MX1200XTPSEK
 MX1200XTSEK
 MX1200XTSEKS

MX1200XT11CK
 MX1200XT31CK
 MX1200XT21CK
 MX1200XT22SEK - MX1200XT22CK
 MX1200XT12SEK - MX1200XT12CK
 MX1200XT32CK



Illustration #	Part #	Description
1	028769-E	Jar Lid Cover
2	028768	Jar Lid
3	503398	Jar with Blending Assembly (64 oz. stackable Raptor)
4	503346	Jar with Blending Assembly (64 oz. stainless steel)
5	503439	Jar with Blending Assembly (48 oz. stackable Raptor 140401 date code)
	503348	Jar with Blending Assembly (48 oz. Eastman)
6	028538	Drive Clutch
7	026442	Jar Pad
7a	026443	Sound Enclosure Jar Pad
8	028824	Motor
9	026437	Dampening Plate Gasket
10	503382-K	MX Housings, Ferrite Core & Cord (CK model)
	028032-09	Black Top Housing
11	028541	Motor Foam (2 Required)
12	026439	Dampening Plate Bushing (4 required)
13	026453	Dampening Plate Sleeve (4 required)
14	026459	Washer (2 required)
15	028929	Screw (4 required)
16	034123	Soft Start Control Panel (XPrep)
	029817	Soft Start Control Panel (Xtreme)
17	028248	Housing Foam Rear Baffle
18	028249	Housing Foam Front Baffle
19	503382-K	MX Housings, Ferrite Core & Cord (CK model)
	028240	Motor Housing
20	002943	Washer (4 required)
21	028247	Bottom Housing Foam Baffle
22	028542	Foam Baffle
23	013731	Cable Tie (3 required) – (2 required older units)
24	503382-K	MX Housings, Ferrite Core & Cord (CK model)
	028680	Cord Set
25	030618	Strain Relief

Catalog

MX1200XTEK
 MX1200XTEKS
 MX1200XTPEK
 MX1200XTPSEK
 MX1200XTSEK
 MX1200XTSEKS

Model

MX1200XT11CK
 MX1200XT31CK
 MX1200XT21CK
 MX1200XT22SEK - MX1200XT22CK
 MX1200XT12SEK - MX1200XT12CK
 MX1200XT32CK

Waring Factory Service Center
 314 Ella T. Grasso Ave.
 Torrington, CT 06790
 Tele. 1-800-269-6640
 Fax 860-496-9017
 www.waringcommercialproducts.com

Illustration #	Part #	Description
26	503382-K 028241-09-x	MX Housings, Ferrite Core & Cord (CK model) Black Bottom Housing
27	012505	Screw (4 required)
28	026430	Corner Post (4 required)
29	028928	Screw (4 Required)
30	028250-E 026432-E	48 oz. Inner Sound Enclosure 64 oz. Inner Sound Enclosure
31	027447	O Ring (2 required)
32	028251-E 026433-E	48 oz. Outer Sound Enclosure 64 oz. Outer Sound Enclosure
33	026461	Screw (3 required)
34	012505	Screw (2 required)
35	026434	Sound Enclosure Handle
36	503397 503345	Blade Assembly (Raptor containers) Blade Assembly
37	024271	O Ring
38	024268	Nut Gasket
39	029631	Bearing Holder Nut
40	503326	64 oz. Stackable Raptor Container ONLY

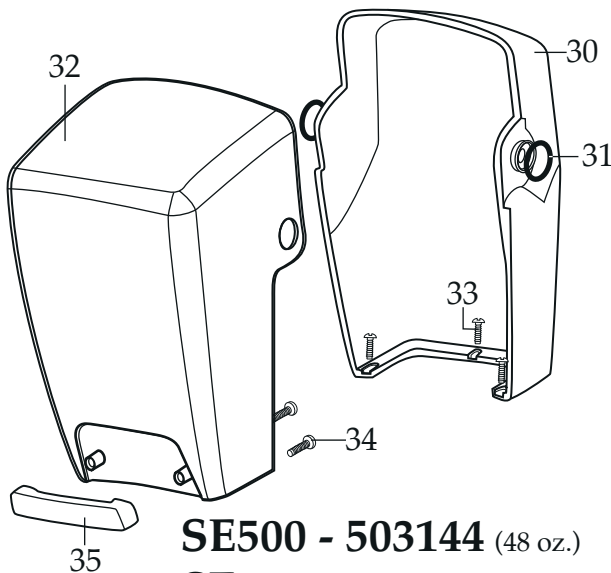

Notes for 503398, 503348 & 503439 :

Torque 100-125 in/lbs

Sealant all around the threads, fill in flats.
 Dow Corning Sealant RTV 733

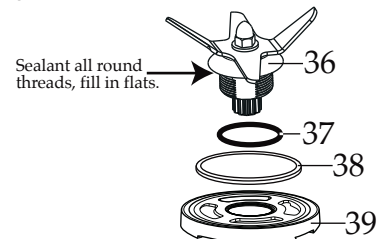
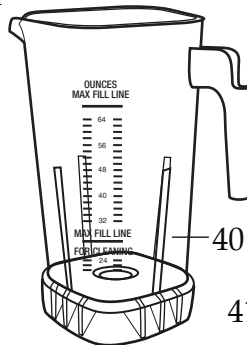

030889
 Blending Assembly Kit
 (Raptor containers)

031060
 Blending Assembly Kit

Catalog

MX1200XTEK
 MX1200XTEKS
 MX1200XTPEK
 MX1200XTPSEK
 MX1200XTSEK
 MX1200XTSEKS

Model

MX1200XT11CK
 MX1200XT31CK
 MX1200XT21CK
 MX1200XT22SEK - MX1200XT22CK
 MX1200XT12SEK - MX1200XT12CK
 MX1200XT32CK

Waring Factory Service Center
 314 Ella T. Grasso Ave.
 Torrington, CT 06790
 Tele. 1-800-269-6640
 Fax 860-496-9017
 www.waringcommercialproducts.com

Illustration #	Part #	Description
41	030888 503308	48 oz. Stackable Raptor Container ONLY 48 oz. Eastman Container ONLY
42	026798	Support Washer
43	026648	64 oz. Stainless Steel Container ONLY
44	026649	Container Support
45	026797	Bearing Holder Gasket
46	026796	Bearing Holder Washer
47	026795	Stainless Steel Jar Bearing Holder Nut

Notes for 503346 :

- Torque 100-125 in/ lbs
- Sealant applied all around indicated areas.
Dow Corning Sealant RTV 733
- Lubricant applied to O Ring
Dow Corning 200 (R) Fluid

